

Data Sheet

aIVR8511 – 85 sec

APLUS INTEGRATED CIRCUITS INC.

Address:

3 F-10, No. 32, Sec. 1, Chenggung Rd., Taipei,
Taiwan 115, R.O.C.
(115)台北市南港區成功路一段 32 號 3 樓之 10.

TEL: 886-2-2782-9266

FAX: 886-2-2782-9255

WEBSITE : <http://www.aplusinc.com.tw>

Sales E-mail:

sales@plusinc.com.tw

Support E-mail:

service@plusinc.com.tw

FEATURES

- | Standard CMOS process.
- | Embedded EPROM.
- | Embedded 8-bit MCU.
- | 85sec voice duration at 6 KHz sampling with 4-bit ADPCM compression.
- | Combination of voice building blocks to extend playback duration.
- | Table entries are available for voice block combinations.
- | User selectable PCM or ADPCM data compress.
- | Voice Group Trigger Options: Edge / Level; Hold / Un-hold; Retrigger / Non-retrigger.
- | Programmable I/Os, Timer Interrupt and Watch Dog Timer.
- | Built-in oscillator with fixed Rosc, software control sampling frequency
- | 2.2V – 3.6V single power supply and < 5uA low stand-by current.
- | PWM Vout1 and Vout2 drive speaker directly with two levels of volume selection.
- | D/A COUT with ramp-up ramp-down option to drive speaker through an external BJT.

DESCRIPTION

Aplus' aIVR8511 is a 8-bit MCU based Voice chip. It is fabricated with Standard CMOS process with embedded voice storage memory. It can store 85sec voice message with 4-bit ADPCM compression at 6KHz sampling rate. 8-bit PCM is also available as user selectable option to improve sound quality. There are eleven programmable I/O pins. Key trigger and Parallel CPU trigger mode can be configured according to different application requirement. User selectable triggering and output signal options provide maximum flexibility to various applications. Built-in resistor controlled oscillator, 8-bit current mode D/A output and PWM direct speaker driving output minimize the number of external components. Two levels volume control for PWM speaker direct drive is available.

PIN CONFIGURATION

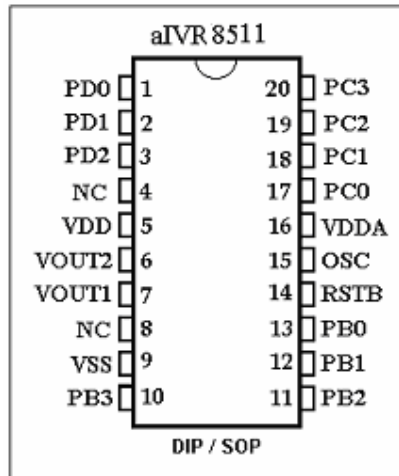

PIN DESCRIPTIONS

Pin Names	Description
VOUT1	PWM output to drive speaker directly
VOUT2_COUT	PWM output or COUT DAC output select by programmable option
VSS	Power Ground
OSC	Oscillator input
VDDA	Positive Power Supply
VDD	Positive Power Supply
PB0~PB3	Programmable I/O port B
PC0~PC3	Programmable I/O port C
PD0~PD2	Programmable I/O port D
RSTB	Reset pin, Low active

Note:

- I PB, PC and PD ports are software programmable I/O pins that can be set to different configurations such as pure input, input with pull-up, input with pull-down and output. The programmable I/O pins set up will take effect immediately after chip RESET is applied.
- I Pins for memory programming are: VDD, VDDA, VSS, PB0, PB1, OSC, VOUT2 and RSTB.

BLOCK DIAGRAM

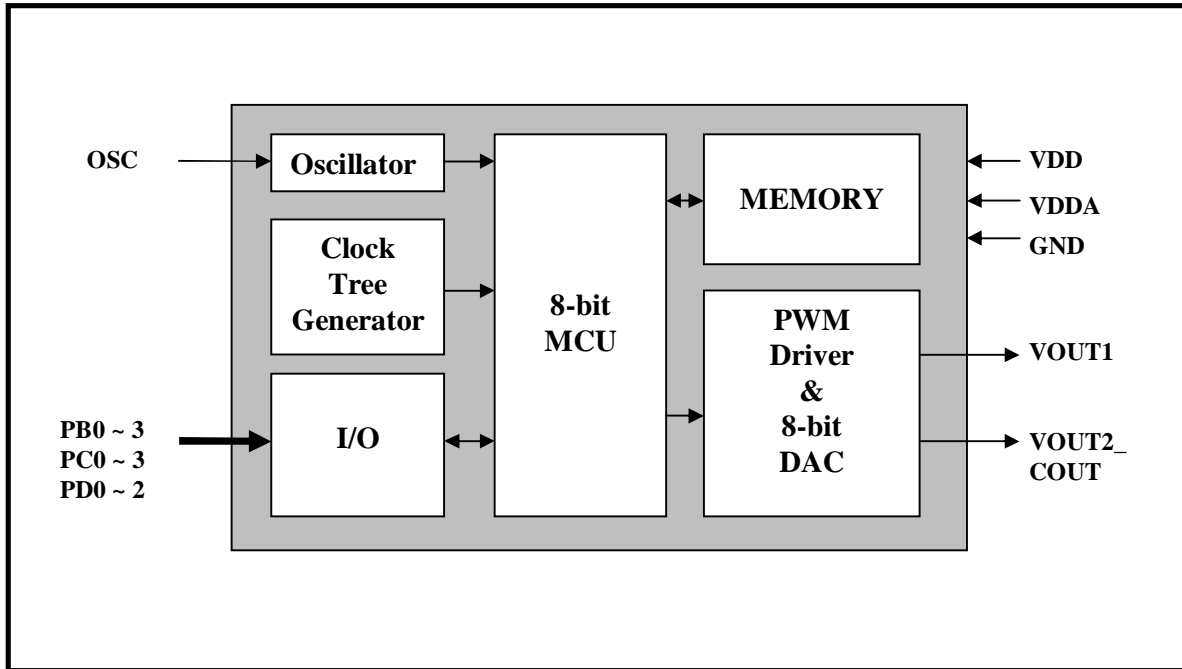

ABSOLUTE MAXIMUM RATINGS

Symbol	Rating	Unit
$V_{DD} - V_{SS}$	-0.5 ~ +4.0	V
V_{IN}	$V_{SS} - 0.3 < V_{IN} < V_{DD} + 0.3$	V
V_{OUT}	$V_{SS} < V_{OUT} < V_{DD}$	V
T (Operating):	-40 ~ +85	°C
T (Junction)	-40 ~ +125	°C
T (Storage)	-55 ~ +125	°C

DC CHARACTERISTICS ($T_A = 0$ to 70°C , $V_{DD} = 3.0\text{V}$, $V_{SS} = 0\text{V}$)

Symbol	Parameter	Min.	Typ.	Max.	Unit	Conditions
V_{DD}	Operating Voltage	2.2	3.0	3.6	V	
I_{SB}	Standby current	—	1	5	μA	I/O properly terminated
I_{OP}	Operating current	—	7	—	mA	I/O properly terminated
V_{IH}	"H" Input Voltage	2.5	3.0	3.5	V	$V_{DD}=3.0\text{V}$
V_{IL}	"L" Input Voltage	-0.3	0	0.5	V	$V_{DD}=3.0\text{V}$
I_{VOUTL_N}	V_{OUT} low O/P Current (Normal Volume)	—	130	—	mA	$V_{out}=1.0\text{V}$
I_{VOUTL_H}	V_{OUT} low O/P Current (High Volume)	—	200	—	mA	$V_{out}=1.0\text{V}$
I_{VOUTH_N}	V_{OUT} high O/P Current (Normal Volume)	—	-130	—	mA	$V_{out}=2.0\text{V}$
I_{VOUTH_H}	V_{OUT} high O/P Current (High Volume)	—	-200	—	mA	$V_{out}=2.0\text{V}$
I_{CO}	C_{OUT} O/P Current	—	-2	—	mA	Data = 80h
I_{OH}	O/P High Current	—	-10	—	mA	$V_{OH}=2.5\text{V}$
I_{OL}	O/P Low Current	—	17	—	mA	$V_{OL}=0.3\text{V}$
R_{NVOUT}	V_{OUT} pull-down resistance	—	100K	—	Ω	V_{OUT} pin set to internal pull-down
R_{NPIO}	Programmable IO pin pull-down resistance	—	1M	—	Ω	PBx, PCx, PDx set to internal pull-down
R_{UPIO}	Programmable IO pin pull-up resistance	3.3K	4.7K	—	Ω	PBx, PCx, PDx set to internal pull-up
$\Delta F_s/F_s$	Frequency stability	-3	—	+3	%	$V_{DD} = 3\text{V} \pm 0.4\text{V}$
$\Delta F_c/F_c$	Chip to chip Frequency Variation	-5	—	+5	%	Also apply to lot to lot variation

TYPICAL APPLICATIONS

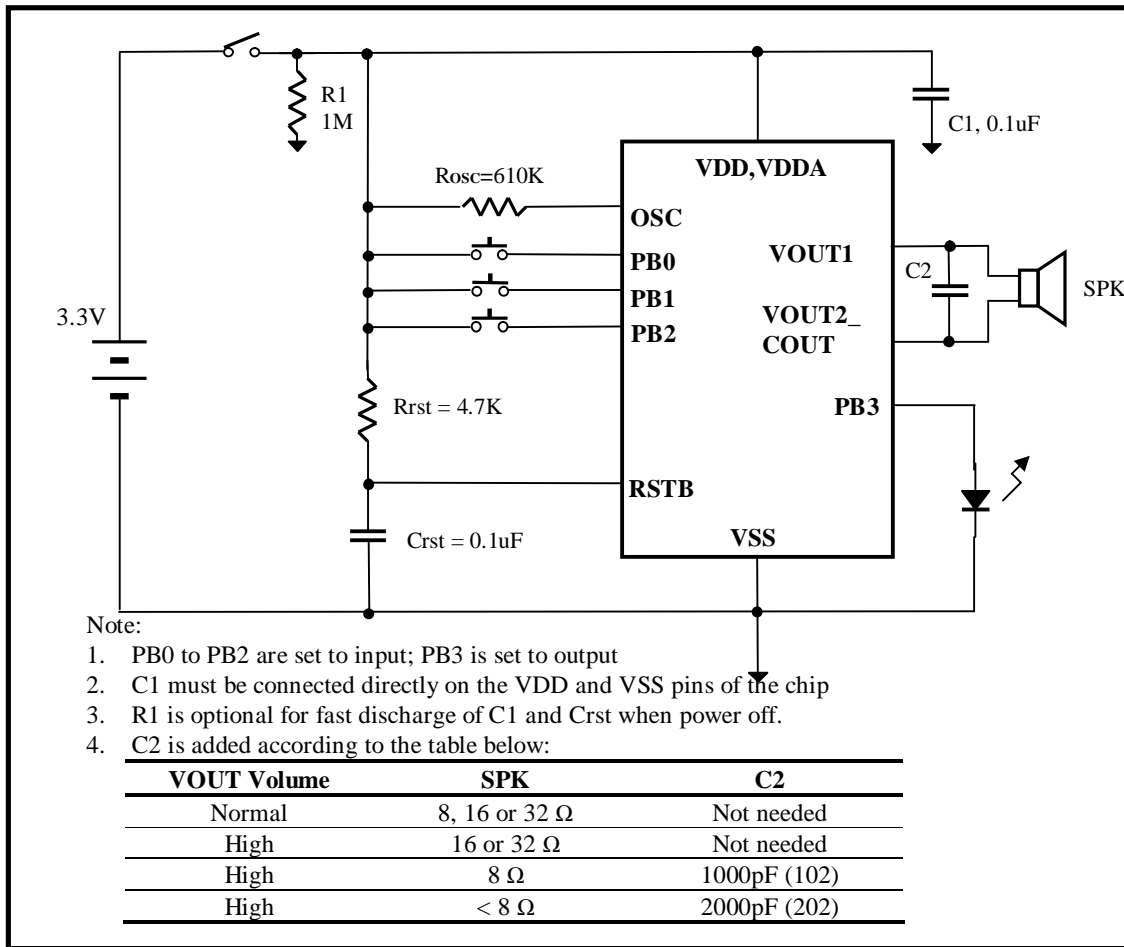

Using 3.3V Battery Direct Drive Speaker

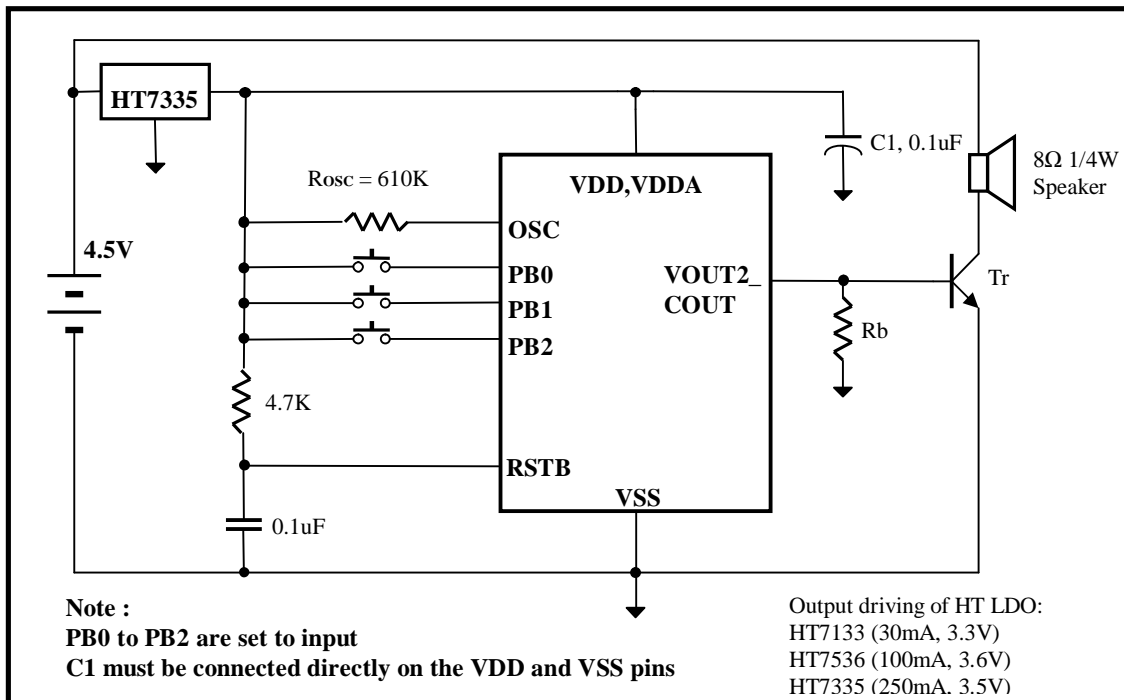

Using 4.5V Battery with COUT speaker drive

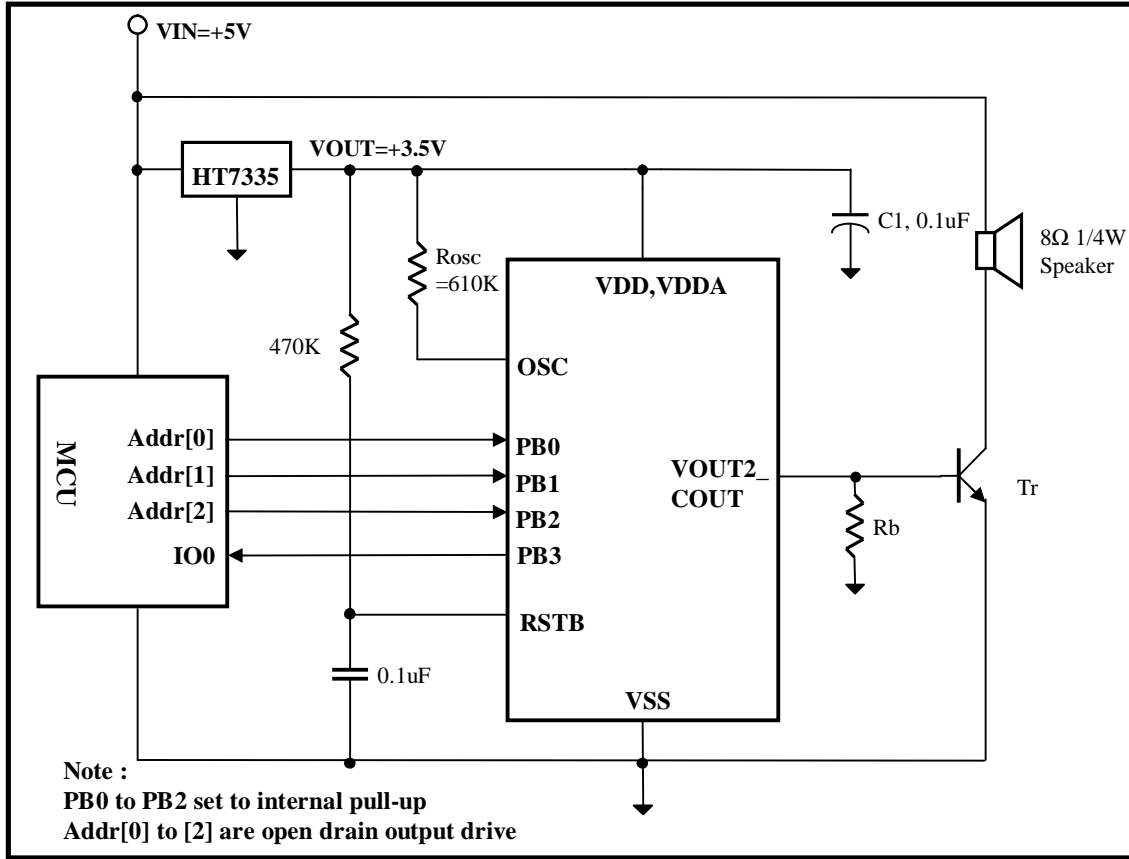

5V CPU Control with COUT

Note for COUT speaker drive:

1. C1 must be connected as close to the chips VDD and VSS pins as possible.
2. Rb is base resistor from 120 Ohm to 390 Ohm depends on value of VDD and transistor gain.
3. Tr is an NPN transistor with beta larger than 150, e.g. 8050D.
4. Rosc = 610K Ohm with Vdd=3.0V can support sampling rate up to 14KHz.
5. For sampling rate higher than 14KHz, smaller value of Rosc should be used.

Bonding Diagrams

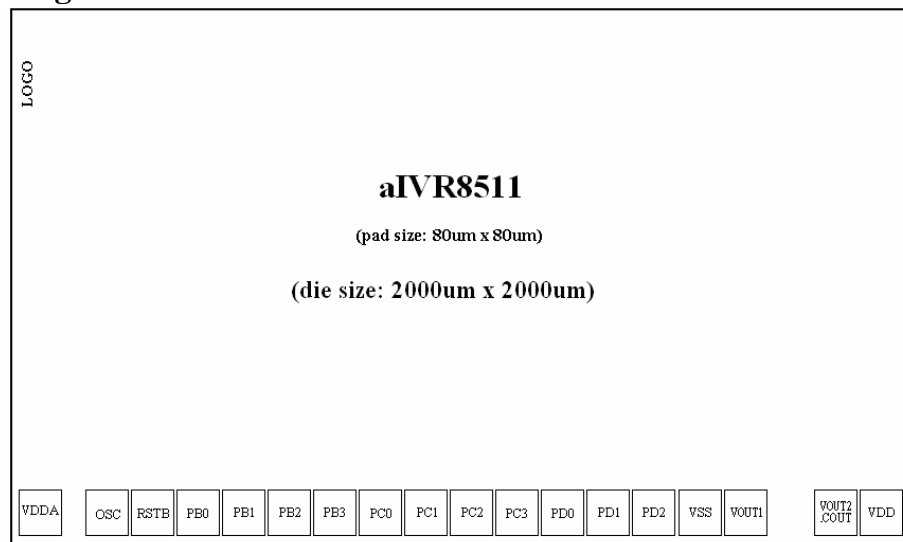

Note: Substrate must be connected to VSS